

# MOORING SOLUTIONS

## SYSTEMS & EQUIPMENT

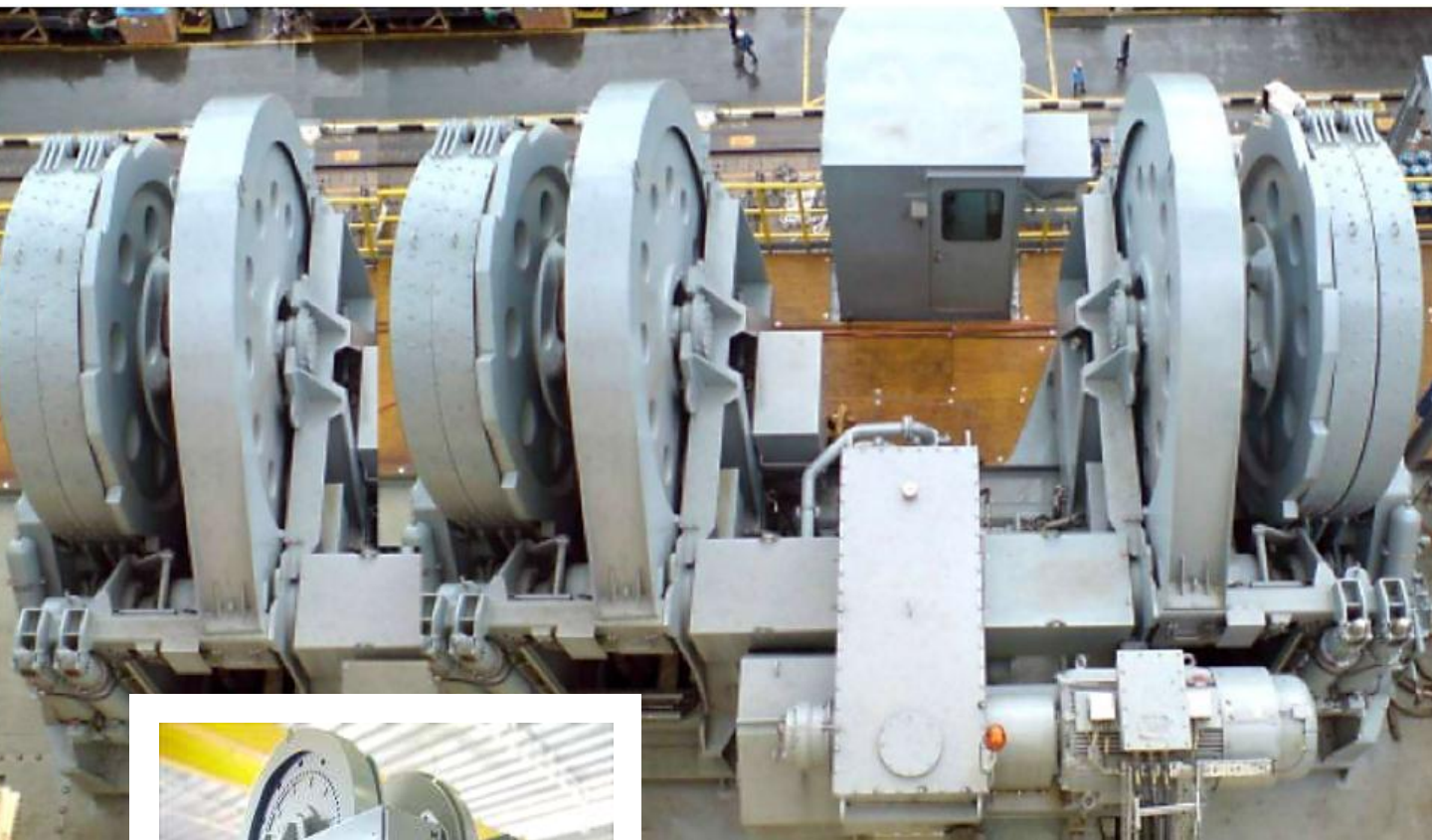

**Keppel**

**Offshore Technology  
Development**

# Mooring Solution Provider for Offshore Mobile Platform



Tailor-made towing and mooring winches for ship

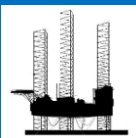

Standardized or tailor-made mooring winches and fairleads for jackup drilling rigs



Other types of winches, including AHTW and mooring systems for FPSO, etc.

**Proven Design**

+

**Branded Components**

+

**OTD Quality Standards**

+

**Cost Effective Manufacturing**

+

**Technical & Commissioning Support**



# What We Do

From 2005, OTD has successfully delivered more than 400 winches for jackup, semi-submersible, and ships worldwide from design to manufacture, and from quality control to testing and inspection, including factory acceptance test (FAT).

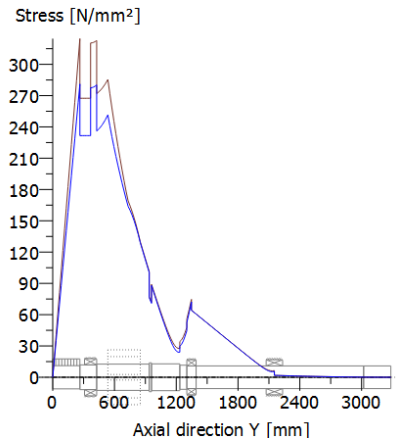
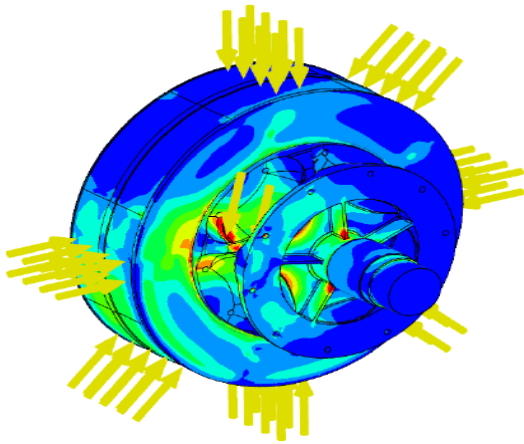
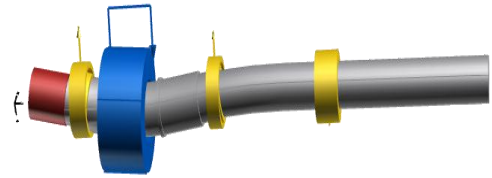
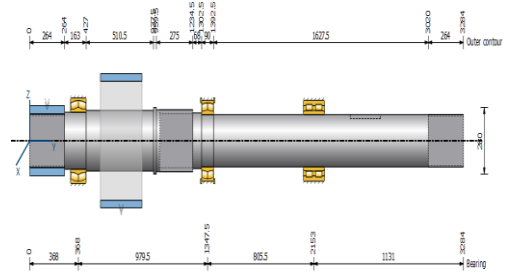
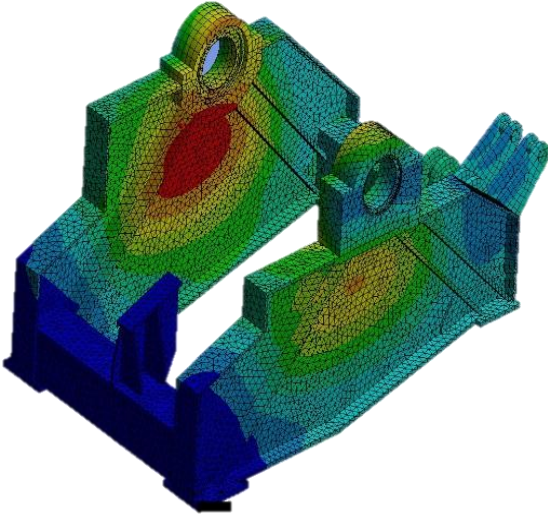

## Design and Engineering

At OTD, all the winches are designed and simulated to worst case scenario to ensure that our winches are able to withstand the harsh environment in the oil and gas industry for years of operation.

With the assistance of advanced analysis software, KISSsoft and ANSYS, OTD delivers the winches with optimized design and in lighter weight.

In order to have better control on the condition of the winches and reduce downtime, gearbox and bearing's Condition Monitoring System are available upon request.

This system would be able to keep a constant watch over the equipment while maximizing the winches' availability and performance.

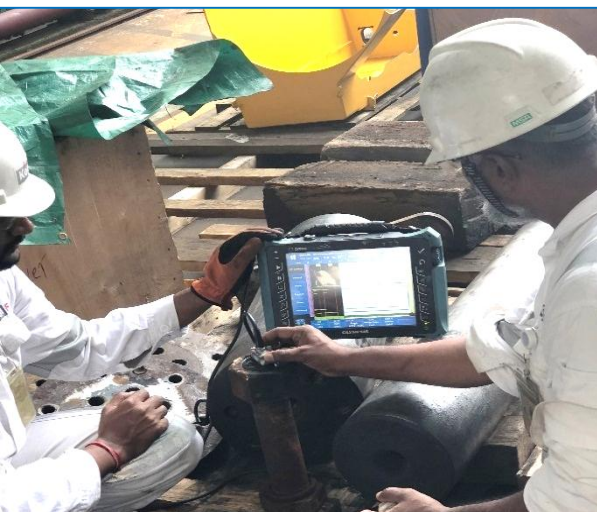

## Quality Control in Manufacturing

To ensure a high quality product is our main priority. We are committed to provide, achieve, and maintain the stringent level of product quality for clients with our uppermost quality control system.

With our latest and ABS-Approved Non Destructive Test (NDT) inspection method – Phased Array Ultrasonic Testing (PAUT), all type defects can be easily checked in shortest time.

In OTD, we care about any single dimension of the components. With our **2-Steps-Verification** approach, every single component that delivered to our valued customer is well controlled.





# Testing and Inspection

In OTD, we do not only perform static pulling test, but also dynamic pulling test as we believe that this is the only way to prove that our designed winches can achieve all the requirements in both static and dynamic conditions before delivering to our clients.

With our dedicated workshop and testing facilities, we could perform 1000mT of static pulling test.

We care about the performance of the auxiliary equipment as well. Our auxiliary equipment will undergo the full load test and only those survived from the test are allowed to be delivered to our clients.



# Mooring Solution for Semi-Submersible

We supply total position mooring solution for semi-submersible drilling rigs in the offshore oil and gas industry. The winches is design as per classification society requirement such as DNV, NMA, ABS, BV, LR, and etc. The brake holding force designed up to 120% of chain MBL.

OTD product range comprises both anchor chain and wire drum for position mooring system. Besides that, OTD offer complete solution which supply underwater fairlead which design to chain/rope MBL, chain stopper for maintenance purpose, deluge system for emergency release and HPU.



Maintenance-free, self lubricated underwater fairlead is designed to chain/rope MBL with wrap and swing angle up to 90 degree.

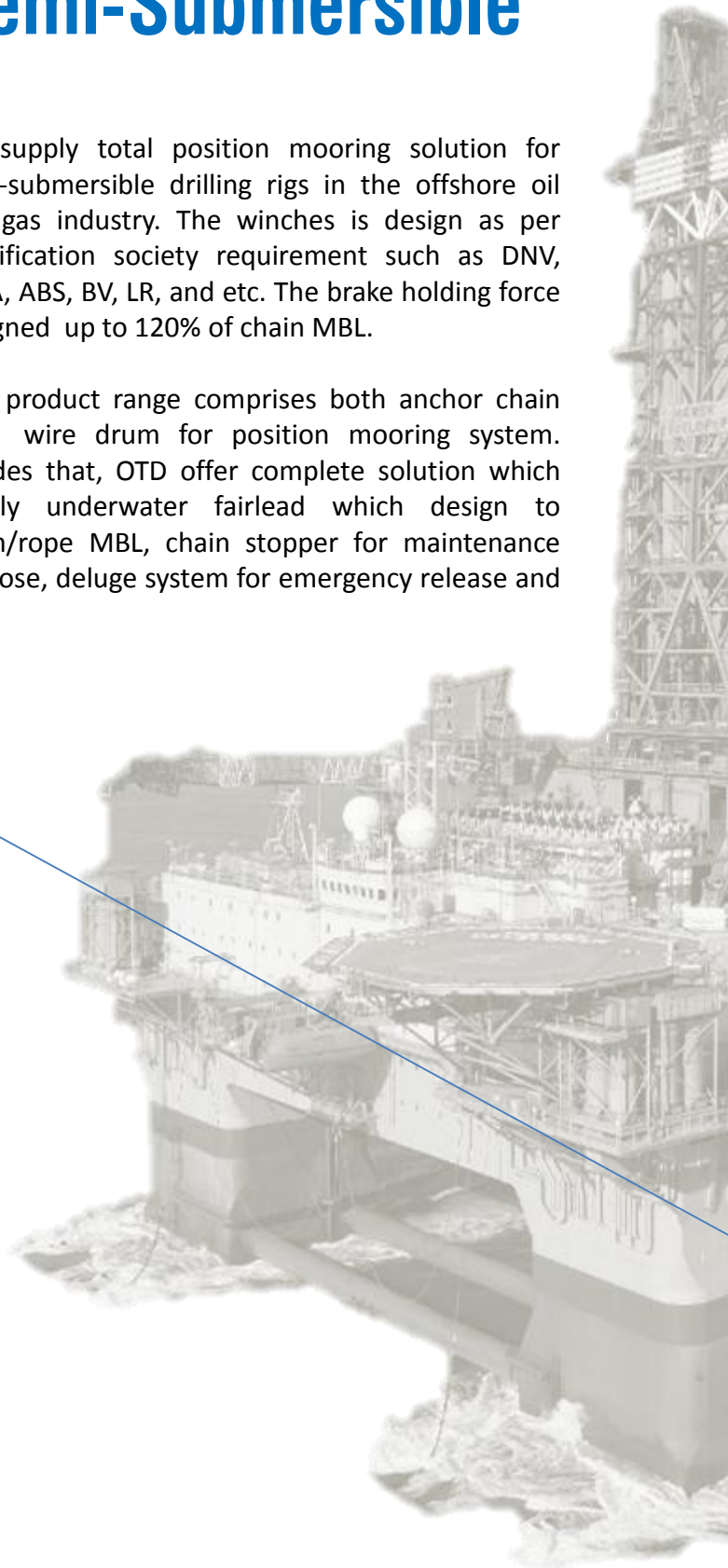



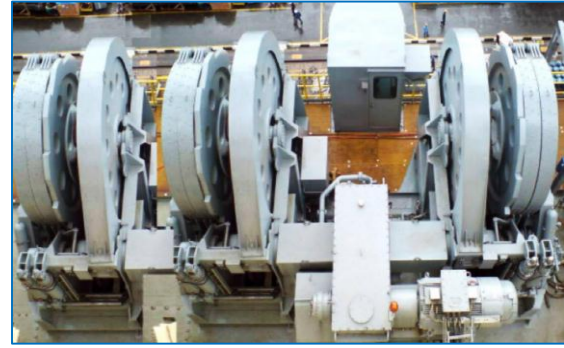

Flexible design enable cable windlass to modify between single, double or even triple configuration for future extension. Different configurations enable rigs to perform 4 points, 8 points , and 12 points position mooring for harsh environment.

### Features

- Compact and robust welding structure
- Freewheeling by water-cooled drag brake
- Fail-safe motor brake
- Fail-safe pneumatic or hydraulic band brake
- Shaft coupling for future extension
- Load and rope length display
- Central remote and local control

OTD product range comprises both anchor chain and wire drum for position mooring system.

Wire rope type winches for position mooring

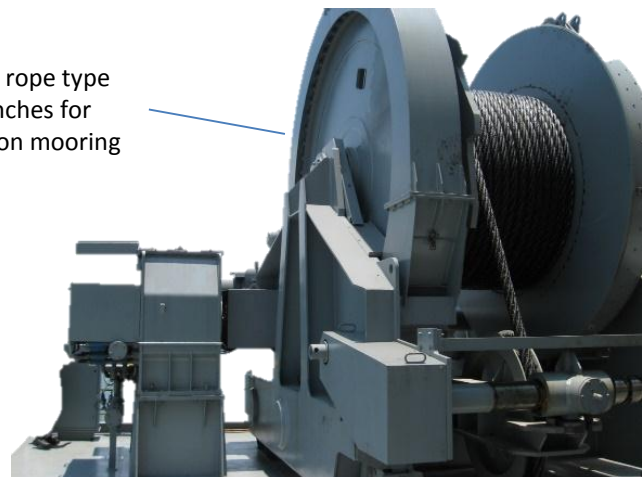

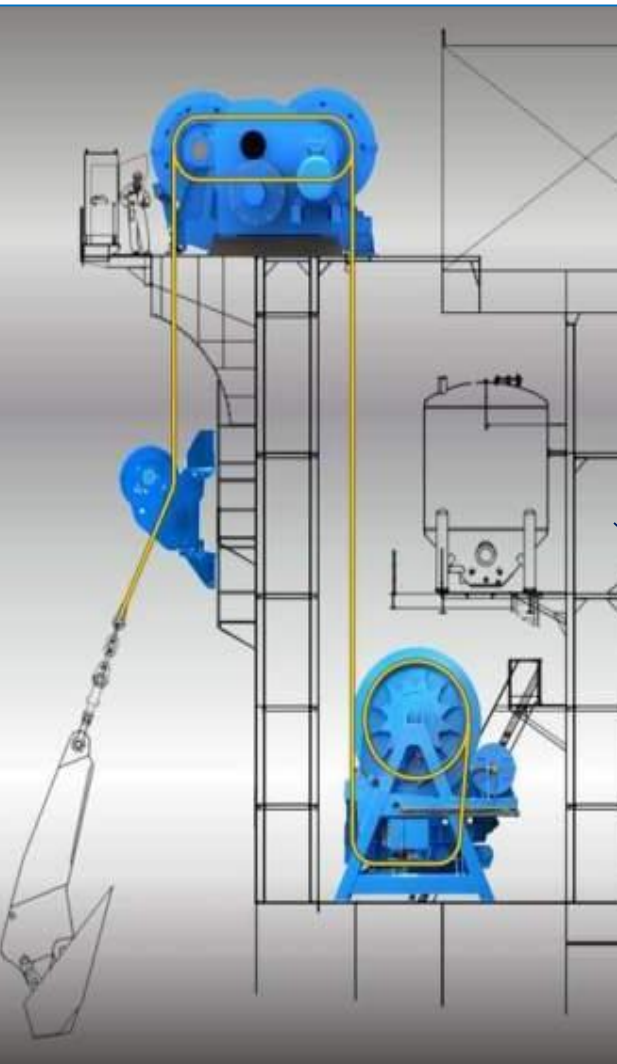

## Specifications

- Nominal pull: 2,000 kN
- Stalling pull: 2,400 kN
- Low speed: 0-10 m/min at 2000 kN
- High speed: 10-20 m/min at 2000-1000 kN
- Storage winch capacity: 1340m x  $\varnothing$ 83mm

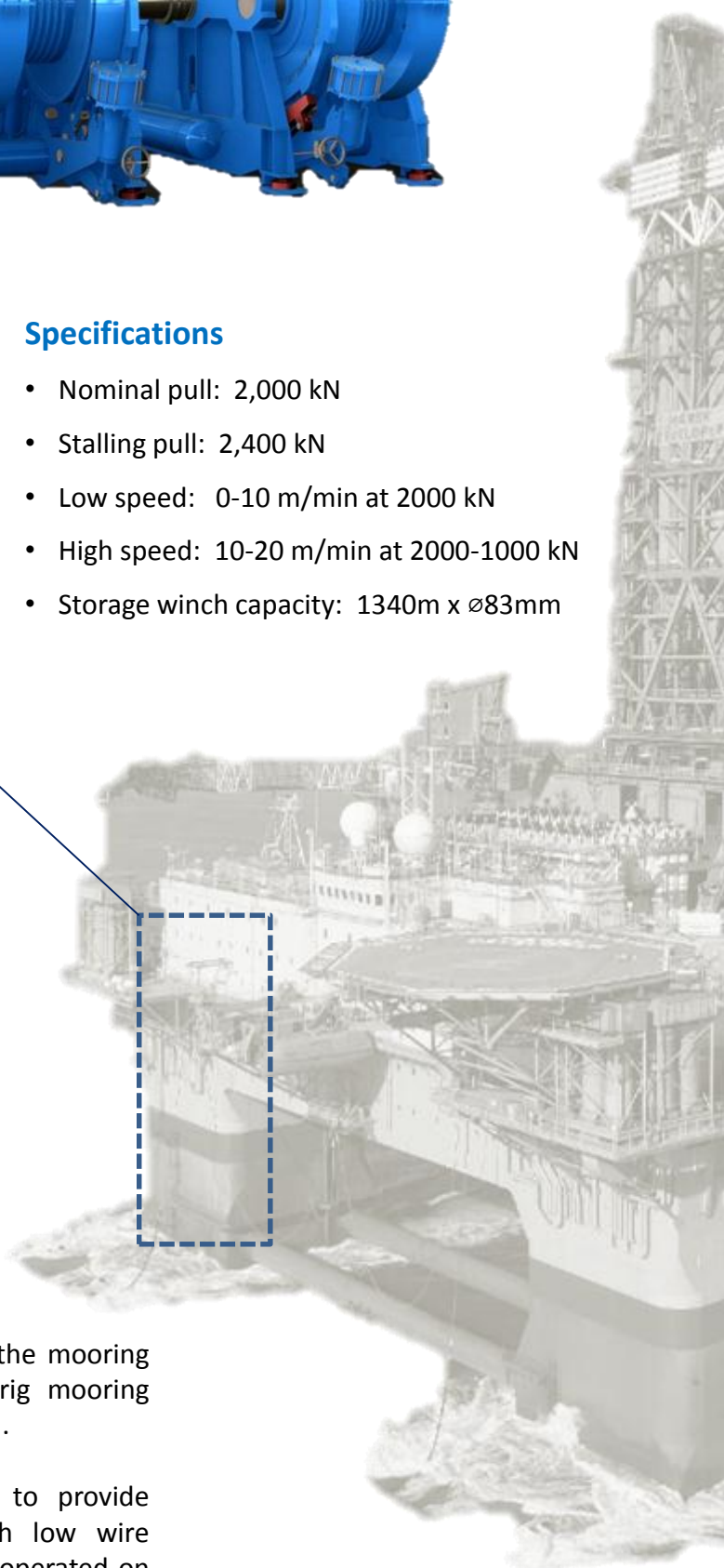

Apart from chain type and rope type of the mooring system, OTD semi submersible drilling rig mooring system also covers traction winches as well.

Traction winch incorporate two drums to provide tension/traction and a third drum with low wire tension for storage. A single rope layer is operated on the traction drums.





Model	Rope Dia. (mm)	Nom. Pull 1 <sup>st</sup> Step (MT X m/min)	Nom. Pull 2 <sup>nd</sup> Step (MT X m/min)	Stall Pull (MT)	Rope Length (m)	Layers	Power (kW)	Brake Holding Force (MT)	Dynamic Pay-out Capacity (MT X m/min)
OTD-AW63	64	70 x 30	105 x 20	77/116	1500	13	415	338	67 x 100
OTD-AW76	76	97 x 30	145 x 20	107/160	1500	13	570	477	100 x 100
OTD-AW89	89	137 x 30	205 x 20	150/226	1500	12	810	670	100 x 100
OTD-AW102	102	177 x 30	265 x 20	195/292	1500	10	1050	860	100 x 100

\*The data provided is for reference only

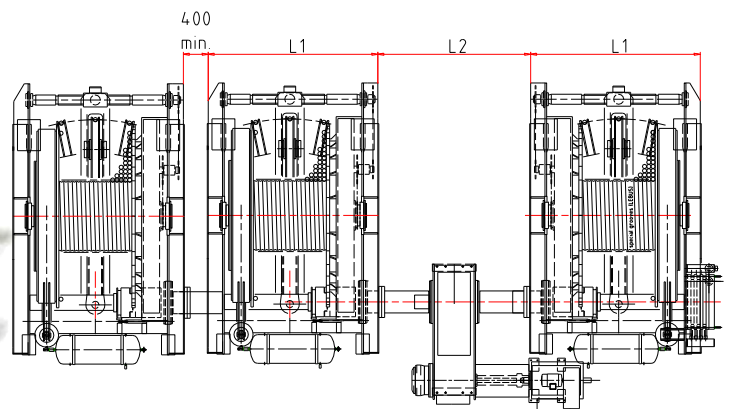
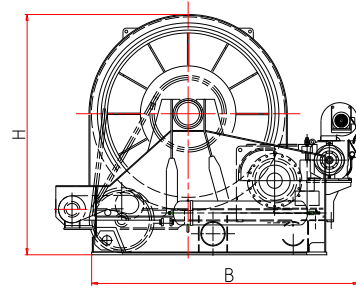

Model	L1 (mm)	L2 (mm)	B (mm)	H (mm)
OTD-AW63	4110	1870	4670	4120
OTD-AW76	4140	1880	4920	4450
OTD-AW89	4240	1900	5595	5030
OTD-AW102	4460	2000	6005	5350

\*The data provided is for reference only

# Mooring Solution for Ships

**Anchor Handling Towing Winch** includes a double drum to handle separate wire ropes for both anchor handling and towing. A remote control panel allows operation from the wheelhouse.

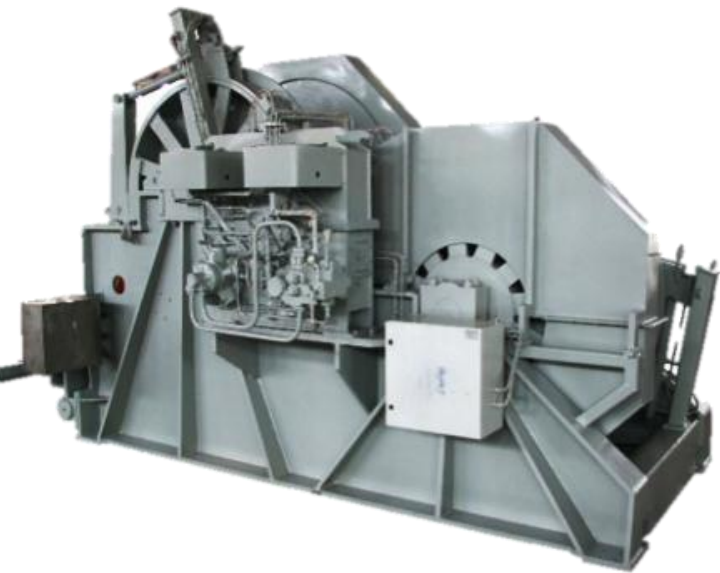

## Features

- Strongly reinforced winch frame to withstand wire breaking load
- Accurate shaft alignment and gear mesh
- Hydraulic operated fail-safe clutch assembly for each drum
- Individual band brake for each drum
- Maintenance friendly with pneumatic gear segment lock
- Control remotely with remote control panel from the wheelhouse

## Specifications

For each anchor handling/towing drum:

- Hoist capacity (1<sup>st</sup> layer): 150MT X 0-7.5m/min  
90MT X 0-11.3m/min  
38MT X 0-28.5m/min
- Lowering capacity (1<sup>st</sup> layer): 0-28.5m/min
- Stall load (1<sup>st</sup> layer): 160MT



**Towing Winch** together with **Anchor Windlass / Towing Winch** are the towing solution for Escort Tug Boat.

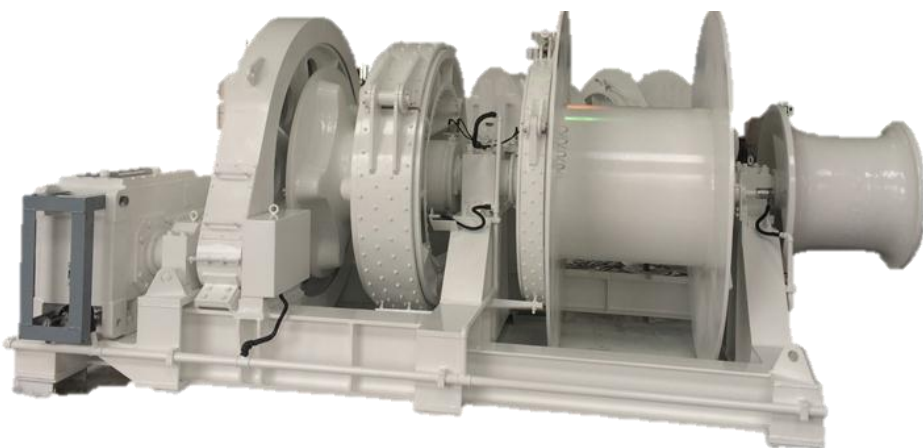
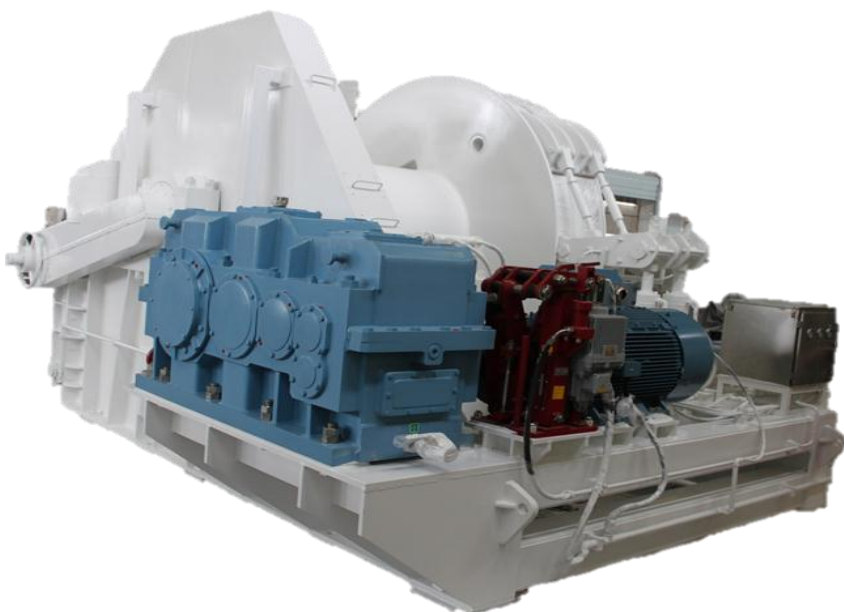

**Combined Anchor Windlass / Mooring Winch** is the typical winches configuration located at the fore ship for the advantage of space saving.

**Double Split Drum Mooring Winch** consists of one tension and one storage drum. Typically only one or two layers of rope are working in tension drum to provide highest pulling force and prevent rope-bite

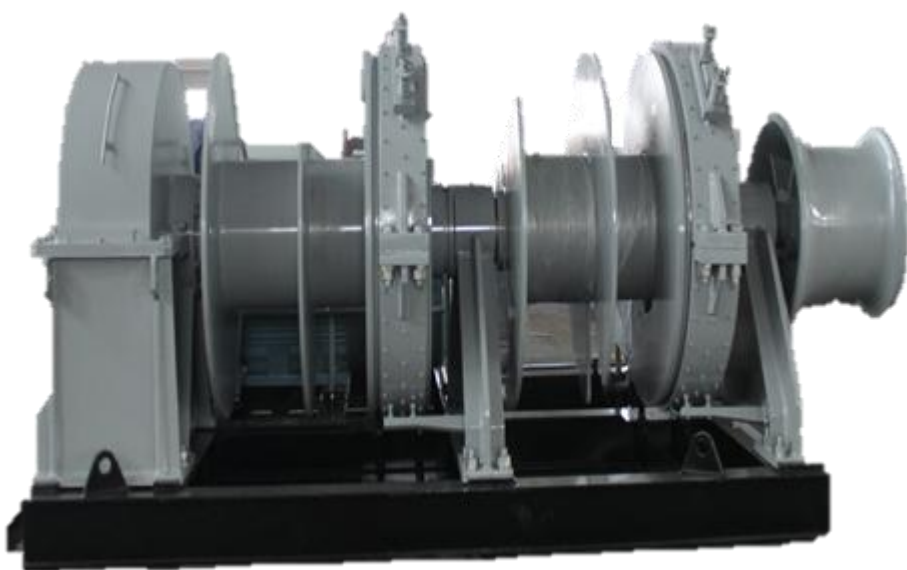



The static and dynamic pulling forces are monitored by two load measuring cell mounted at the front of winches skid frame to provide safe operation.

# Mooring Solution for Jackup

We supplied more than 400 winches in 70 operating jackup rigs and 30 in production for the offshore oil and gas industry worldwide.

Our strong track record and experience enables us to provide effective solution to optimise winches performance without compromising on the safety of winches.

OTD offers complete mooring solution which supply swivel fairleader and guide sheave which are designed to chain/rope MBL.

Standardised winches are ranged for nominal pull from 25Tonne up to 180Tonne and the brake holding capacity up to 395Tonne.

Different water depth and drilling depth require different capacity of the winches and its solution. OTD standardised winches covered most of them and tailor-made for standardised solution are available to meet special Jack up.

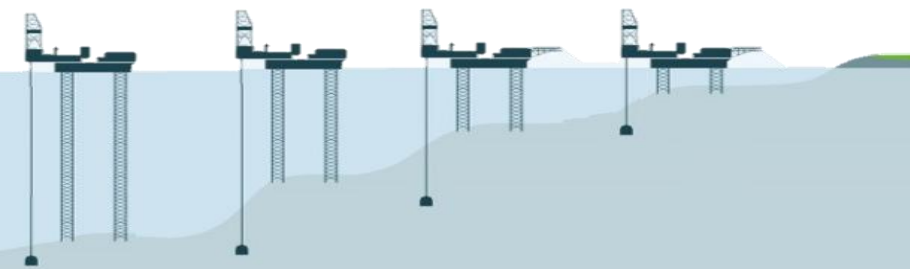
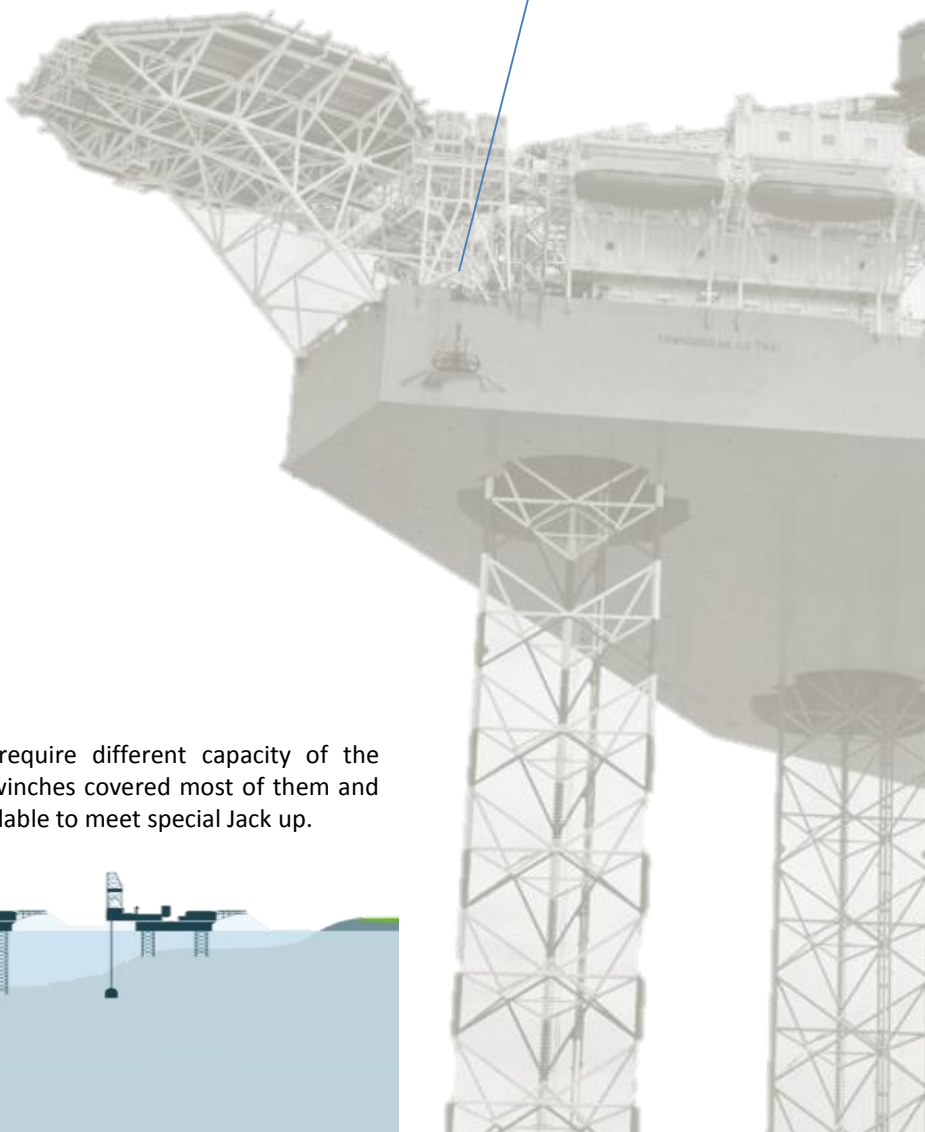



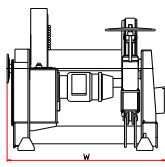
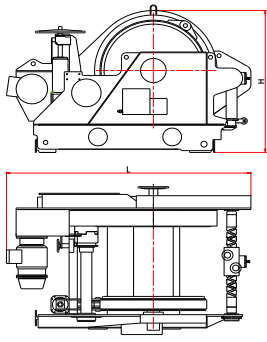

Model	Pull X Speed (MT X m/min)	Brake Holding Capacity (MT)	Wire Rope Spooling Length and Diameter Capacity (m X mm)	Winch Dimensions L X W X H (mm X mm X mm)	Weight (MT)	Motor Power (kW)
OTD-MW025	25 X 5.8	60	775 x Ø38	3580 X 2320 X 2200	9.5	27
OTD-MW030	30 X 5.8	60	775 x Ø38	3580 X 2350 X 2300	10.2	32
OTD-MW040	40 X 5.8	100	915 x Ø38	3950 X 2320 X 2300	14	45
OTD-MW060	60 X 5.5	180	1000 x Ø51	4350 X 3465 X 2705	23.5	65
OTD-MW085	85 X 3.7	220	1050 x Ø58	3545 X 4420 X 3370	29	64
OTD-MW180	180 X 10	395	1300 x Ø76	5730 X 4690 X 4430	60	350

\*The data provided is for reference only

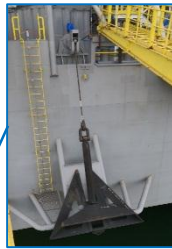

Swivel fairlead is designed to chain/rope MBL and option for bolted and welded mounting solution. Standardised fairlead are design from steel wire rope up to 58mm. Tailor made are available for different size of the rope diameter.

## Features

- Single or double drum, electrical drive
- Direct on Line (DOL) or Variable Frequency Drive (VFD)
- Single speed or 2-speed motor
- Integrated modular gear box
- Fail-safe motor brake
- Pneumatic fail-safe band brake with manual emergency release
- Auto clutch with manual override
- Load and rope length display
- Controlled from local control console
- Optional remote control
- Cost effective

4 x 300kN Winch are design for jackup with water depth 400 feet and drilling depth 30,000 feet

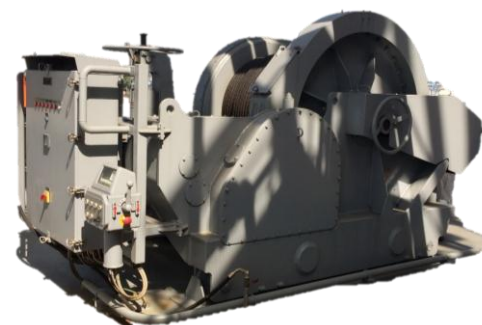

# Mooring Solution for FPSO

OTD supplies the mooring system for the FPSO, which include Riser Pull-In System and Chain Jack System.

Riser Pull-In System



Chain Jack System

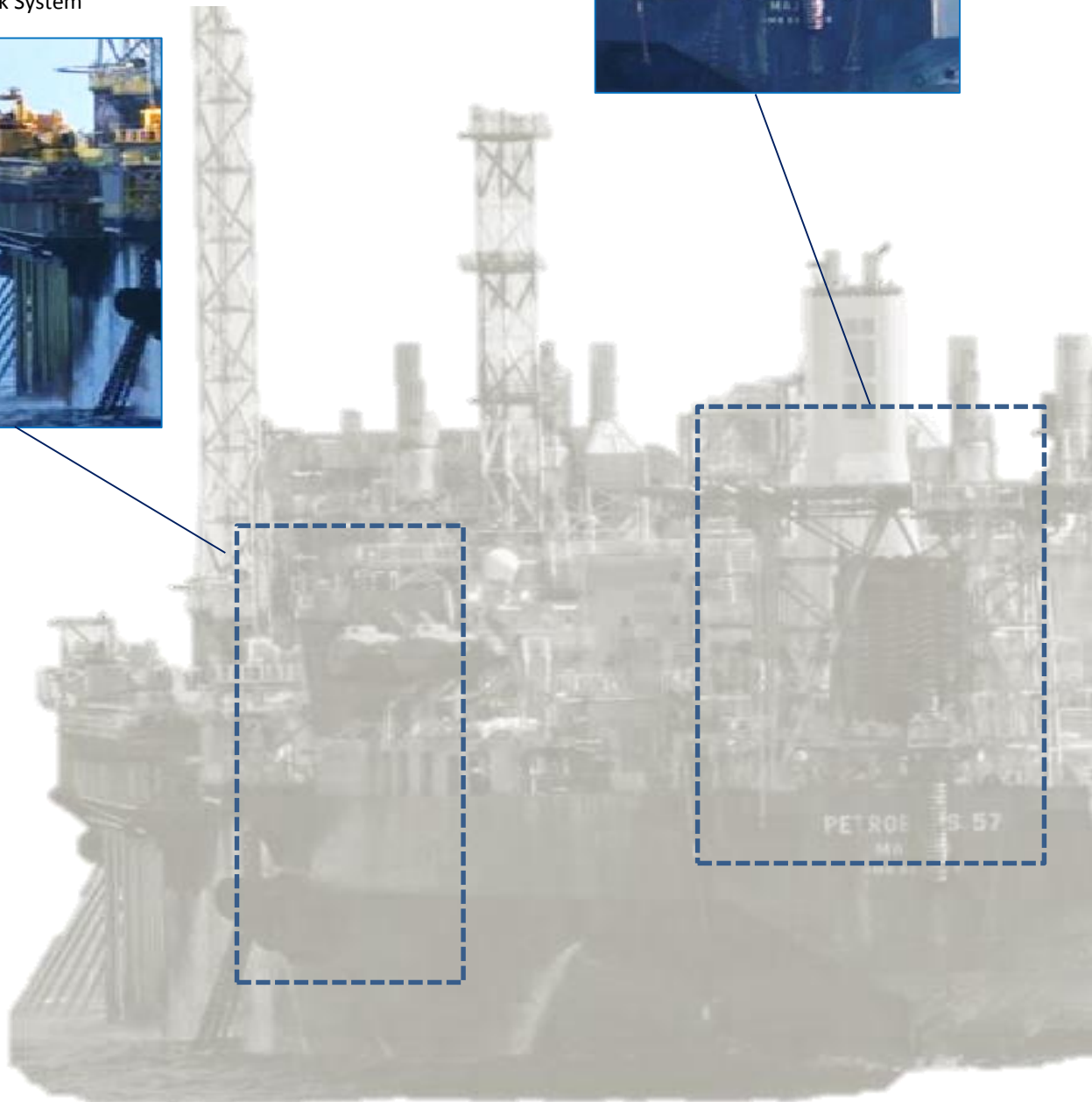



# Our Track Record

Since 2005, OTD has delivered hundreds of heavy duty winches for more than 80 jackup and semi-submersible rigs. These are high specifications winches customised according to our customers' requirements.

## Jack-Up Drilling Rigs

HULL No.	OWNER	Vessel Name
B260	NDC	Al-Hail
B263	Aban	Deep Driller 2
B267	Aban	Deep Driller 3
B271	Aban	Deep Driller 5
B284	Aban	Deep Driller 6
B289	Aban	Deep Driller 8
B269	COSL	COSL Craft
B285	COSL	COSL Boss
B293	COSL	COSL Strike
B273	Maersk	Maersk Resilient
B274	Maersk	Maersk Resolute
B275	Maersk	Maersk Resolve
B276	Maersk	Maersk Reache
B277	Safin	Paradise 400
B291	Seadrill	West Ariel
B311	Seadrill	West Callisto
B312	Chernomorneftegaz	Piter Godovanets
B283	GDI	Al-Zubarah
B290	Jindal	Discovery I
B292	Jindal	Virtue I
B294	Greatship	Greatdrill Chetna
B297	Greatship	Greatdrill Chitra
B300	Rowan	Rowan Viking
B301	Rowan	Rowan Stavanger
B306	Rowan	Rowan Norway
B317	Workfox	Seafox 5
B319	Chernomorneftegaz	Nezalezhnist
B320	Seadrill	AOD I
B321	Seadrill	AOD II
B324	UMW	UMW Naga 4
B325	Arab Drilling	Arab Drill 50
B326	Borr Drilling	Odin
B327	Borr Drilling	Idun
B328	Oro Negro	Primus
B329	Ensco	Ensco 120
B330	Ensco	Ensco 121
B331	Maersk	Intrepid

HULL No.	OWNER	Vessel Name
B332	Maersk	Interceptor
B333	JDC	Hakuryu 11
B334	Vision Drilling	Dynamic Vision
B335	Borr Drilling	Mist
B336	Oro Negro	Laurus
B337	CP Latinas	La Santa Maria
B338	CP Latinas	La Covadonga
B339	Arab Drilling	Arab Drill 60
B340	UMW	UMW Naga 5
B341	GDI	Les Hat
B342	GDI	Dukhan
B345	Seadrill	AOD III
B346	Ensco	Ensco 122
B347	Maersk	XLE3
B351	Arab Drilling	Arab Drill 70
B352	Clear Water	
B353	Star Drilling	Jindal Explorer
B354	Grupo R	Cantarell 1
B355	Grupo R	Cantarell 2
B356	Grupo R	Cantarell 3
B357	Grupo R	Cantarell 4
B359	Ensco	Ensco 110
B360	Grupo R	Paraiso I
B361	Grupo R	Paraiso II
B363	PetroVietnam	PV Drilling VI
B364	Borr Drilling	Saga
B365	Borr Drilling	Skald
B366	Borr Drilling	Tivar
B367	Borr Drilling	Vale
B368	Borr Drilling	Var
B369	Ensco	Ensco 123
B371	Fecon	
B372	Fecon	
B373	Fecon	
B376	UMW	UMW Naga 8
M1222	Keppel FELS	
M1286	Keppel FELS	Can Do Barge 2

## Semi-Submersible Drilling Rigs

HULL No.	OWNER	Vessel Name
B280	Maersk	Maersk Developer
B281	Maersk	Maersk Discoverer
B295	Maersk	Maersk Deliverer
B286	Ensco	Ensco 8500
B287	Ensco	Ensco 8501
B298	Ensco	Ensco 8502
B303	Ensco	Ensco 8503

HULL No.	OWNER	Vessel Name
B308	Ensco	Ensco 8504
B310	Ensco	Ensco 8505
B315	Ensco	Ensco 8506
B288	Transocean	Development Driller III
B296	Queiroz Galvao	Gold Star
B309	Queiroz Galvao	Alpha Star
B316	PetroVietnam	PV Drilling V

## Semi-Submersible Accommodation Vessels

HULL No.	OWNER	Vessel Name
B261	Prosafe	Consafe Concordia
B302	Floatel	Floatel Superior
B307	Floatel	Floatel Reliance

HULL No.	OWNER	Vessel Name
B343	Floatel	Floatel Victory
B348	Floatel	Floatel Endurance
B362	Floatel	Floatel Triumph

# Partnering with



## Our Clientele



FTS Derricks Pte Ltd



**Keppel**

**Offshore Technology  
Development**

55 Gul Road, Singapore 629353

Tel : (65) 6863 7409

Fax : (65) 6862 3465

Enquiries : enquiry@keppelotd.com

Support : support.otd@keppelotd.com

Web : www.keppelom.com/otd